

# MX-X Technical Data

## Very Narrow Aisle Truck (man-up)

---

MX-X/Li-Ion

MX-X iGo systems



**iGo systems**

first in intralogistics

MX-X Very Narrow Aisle Truck (man-up)  
Perfection in Performance and Comfort



				STILL	STILL	STILL	STILL
Features	1.1	Manufacturer					
	1.2	Manufacturer's type designation		<b>MX-X/Li-Ion with turret head</b>	<b>MX-X/Li-Ion with turret head</b>	<b>MX-X/Li-Ion with telescopic fork</b>	<b>MX-X/Li-Ion with telescopic fork</b>
	1.3	Drive		Electric	Electric	Electric	Electric
	1.4	Operation		Stand-on/rider seated	Stand-on/rider seated	Stand-on/rider seated	Stand-on/rider seated
	1.5	Rated capacity/load		Q kg 1500 (iGo systems 1400)	1250 (iGo systems: 1150)	1250 (iGo systems: 1150)	1250 (iGo systems: 1150)
	1.6	Load centre		c mm 600	600	600	600
Weights	1.9	Wheel base		y mm 1992	2212	1992	2212
	2.1	Service weight (incl. battery)		kg 8410	11150	8088	10871
	2.2	Axle load with load		drive end/load end kg 2573/7337	3698/8702	2384/6954	3505/8615
Tyres/chassis	2.3	Axle load without load		drive end/load end kg 3362/4972	4349/6801	3173/4915	4220/6651
	3.1	Tyres		Vulkollan	Vulkollan	Vulkollan	Vulkollan
	3.2	Tyre diameter/width		drive end mm 406/170	406/170	406/170	406/170
	3.3	Tyre diameter/width		load end mm 370/160	370/160	370/160	370/160
	3.5	Number of wheels (x = driven)		drive end/load end 1x/2	1x/2	1x/2	1x/2
	3.6	Track width		drive end/load end b <sub>10</sub> /b <sub>11</sub> mm 1245/0	1595/0	1145/0	1295/0
Basic dimensions	4.2	Height		mast lowered h <sub>1</sub> mm 3900	5400	3400	5400
	4.3	Free lift		h <sub>2</sub> mm -	4150	-	4150
	4.4	Lift		h <sub>3</sub> mm 5200	11550	4200	11550
	4.5	Height		mast extended h <sub>4</sub> mm 7785	14135	6785	14135
	4.7	Height of overhead guard (cabin)		h <sub>6</sub> mm 2555	2555	2555	2555
	4.8	Stand height, lowered		h <sub>7</sub> mm 460	460	460	460
	4.11	Auxiliary fork lift		h <sub>9</sub> mm 1800	1800	800	800
	4.14	Stand height, raised		h <sub>12</sub> mm 5660	12010	4660	12010
	4.14.1	Reach height (h <sub>12</sub> + 1600)		h <sub>28</sub> mm 7260	13610	6260	13610
	4.15	Height lowered		h <sub>13</sub> mm 60	60	380	380
	4.19	Overall length (incl. fork)		l <sub>1</sub> mm 3622	3937	3847	4067
	4.21	Overall width, load wheel axle		b <sub>1</sub> /b <sub>2</sub> mm 1160/1450	1160/1800	1160/1350	1160/1500
	4.22	Fork dimensions		s/e/l mm 50/120/1190	50/120/1205	65/174/1200	65/174/1200
	4.24	Width of fork carriage		b <sub>3</sub> mm 710	710	830	830
	4.25	Outer fork width		min./max. b <sub>5</sub> mm 470/640	470/640	545/545	545/545
	4.27	Width over guide rollers		b <sub>6</sub> mm 1640	1870	1475	1595
	4.29	Shift, sideways		b <sub>7</sub> mm 1305	1398	1340	1400
	4.31	Floor clearance with load, beneath mast		m <sub>1</sub> mm 40	40	40	40
	4.32	Floor clearance centre wheel base		m <sub>2</sub> mm 87	87	87	87
	4.34	Working aisle width		A <sub>st</sub> mm 1645	1875	1480	1600
	4.35	Turning radius		W <sub>a</sub> mm 2248	2468	2248	2468
4.38	Distance fork pivot point		l <sub>8</sub> mm 1019	1114	1269	1269	
4.39	Length of shift carriage		A mm 480	575	-	-	
4.40	Width of shift frame		B mm 1465	1540	-	-	
4.41	Width of shift carriage		F mm 250	310	-	-	
4.42	Width of transition aisle, min.		A <sub>u</sub> mm 4041	4466	4222	4442	
4.44	Clear width cabin access		mm 412	412	412	412	
4.45	Headroom clearance cabin		mm 2000	2000	2000	2000	
Performance data	5.1	Driving speed		laden/unladen km/h 14.0/14.0	12.0/12.0	14.0/14.0	12.0/12.0
	5.1.1	Driving speed iGo systems, inductive guidance		laden/unladen km/h 7.2/7.2	7.2/7.2	7.2/7.2	7.2/7.2
	5.1.2	Driving speed iGo systems, mechanical guidance		laden/unladen km/h 10.8/10.8	10.8/10.8	10.8/10.8	10.8/10.8
	5.2	Lift speed		laden/unladen m/s 0.6/0.6	0.48/0.53	0.6/0.6	0.48/0.53
	5.3	Lowering speed		laden/unladen m/s 0.45/0.45	0.45/0.45	0.45/0.45	0.45/0.45
	5.4	Shift speed		laden/unladen m/s 0.29/0.29	0.30/0.30	0.25/0.25	0.25/0.25
5.9	Acceleration time (10 m)		laden/unladen s 6/6	7/7	6/6	7/7	
5.10	Service brake		Regenerative	Regenerative	Regenerative	Regenerative	
Electric engine	6.1	Drive motor, capacity S2 = 60 min		kW 7.0	7.0	7.0	7.0
	6.2	Lift motor, capacity S3 = 15 %		kW 24.0	24.0	24.0	24.0
	6.3	Battery according to IEC 254-2; A, B, C, no		IEC 254-2; A	IEC 254-2; A	IEC 254-2; A	IEC 254-2; A
	6.4	Battery type, voltage, rated capacity K <sub>s</sub>		V/Ah PzS, 80 V, 700 Ah	PzS, 80 V, 930 Ah	PzS, 80 V, 700 Ah	PzS, 80 V, 930 Ah
	6.5	Battery weight ±5% (depends on manufacturer)		kg 1863	2178	1863	2178
Misc.	8.1	Type of truck control microprocessor		Microprocessor	Microprocessor	Microprocessor	Microprocessor
	8.4	Sound level, driver's ear		dB(A) 68	68	68	68

MX-X Very Narrow Aisle Truck (man-up)  
 Technical Drawings

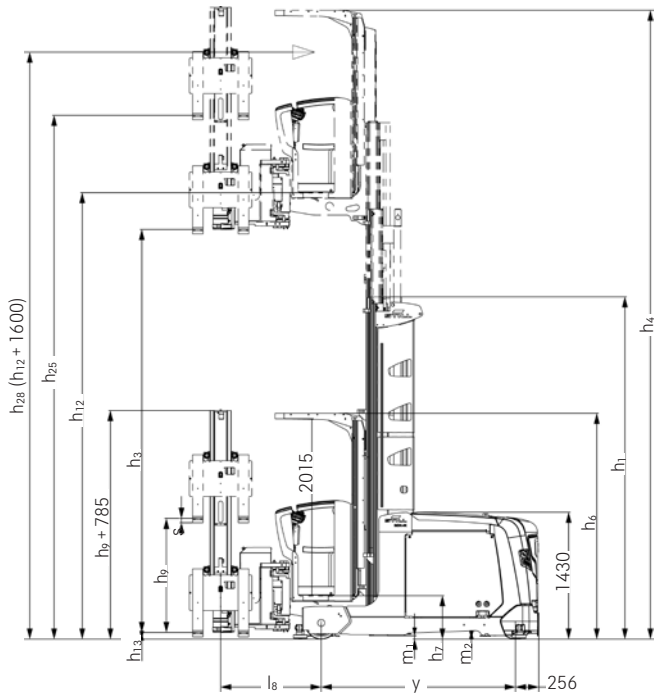

MX-X with turret head - side view

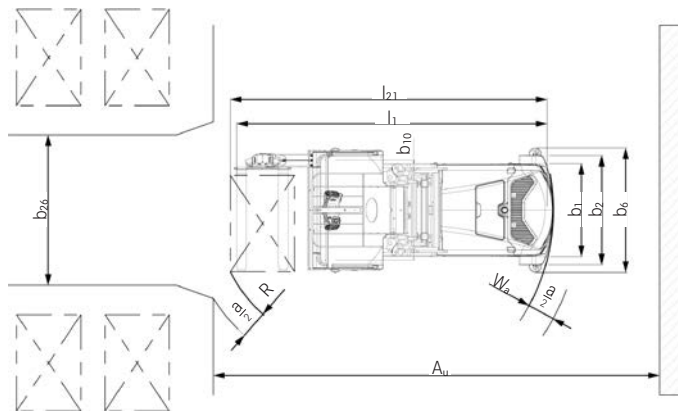

MX-X with turret head and mechanical guidance - top view

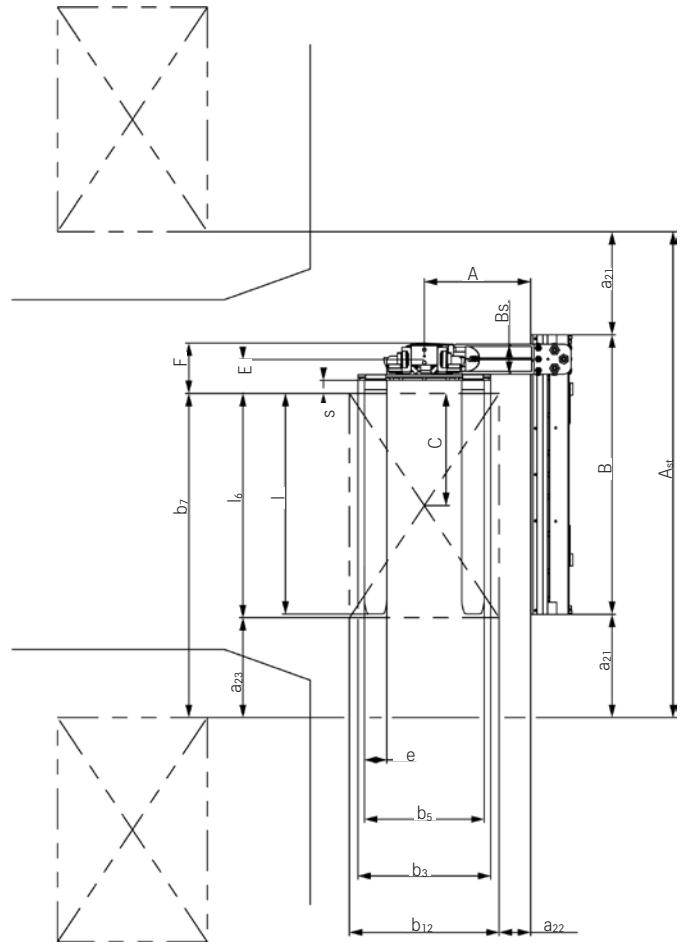

Turret head - top view

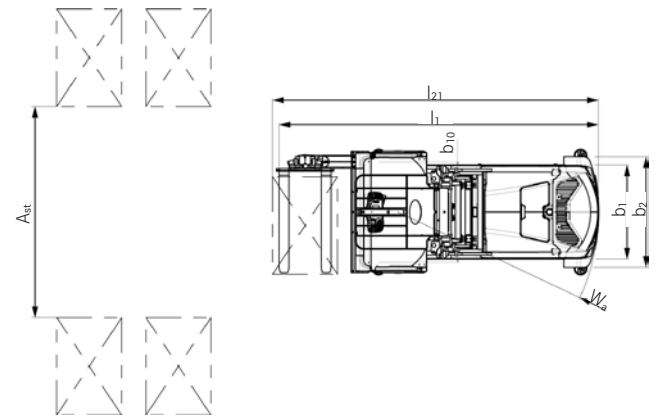

MX-X with turret head and inductive guidance - top view

MX-X Very Narrow Aisle Truck (man-up)  
 Technical Drawings

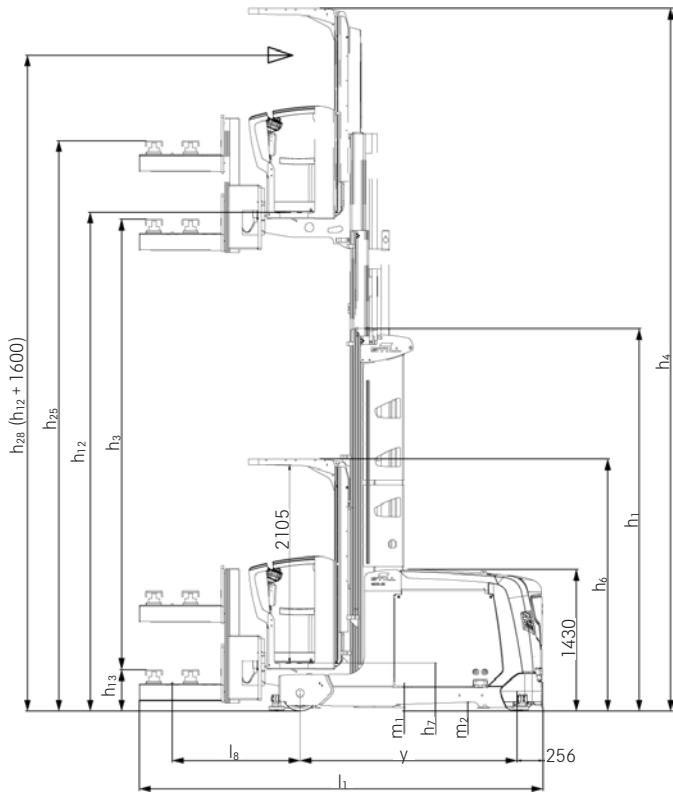

MX-X with telescopic fork - side view

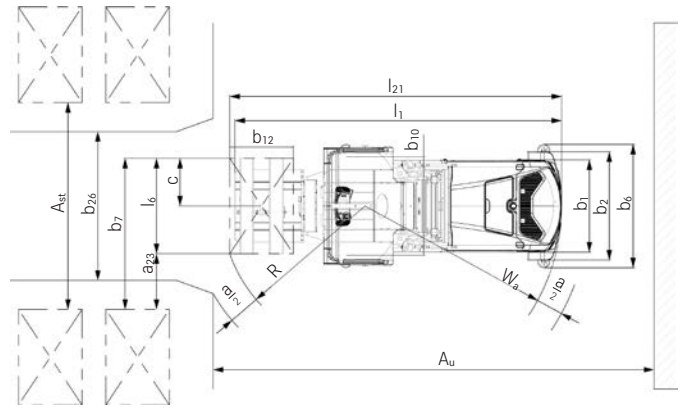

MX-X with telescopic fork and rail guidance - top view

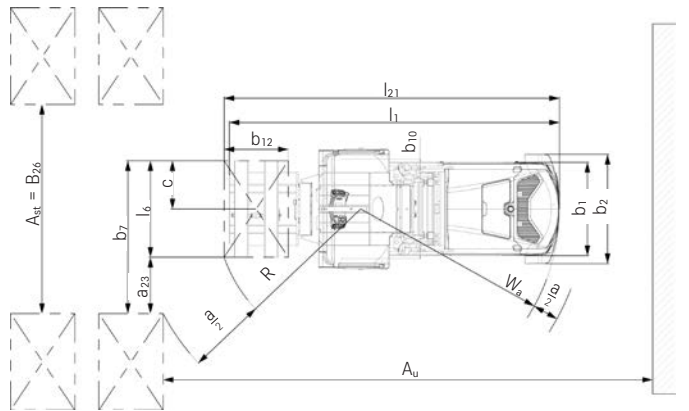

MX-X with telescopic fork and inductive guidance - top view

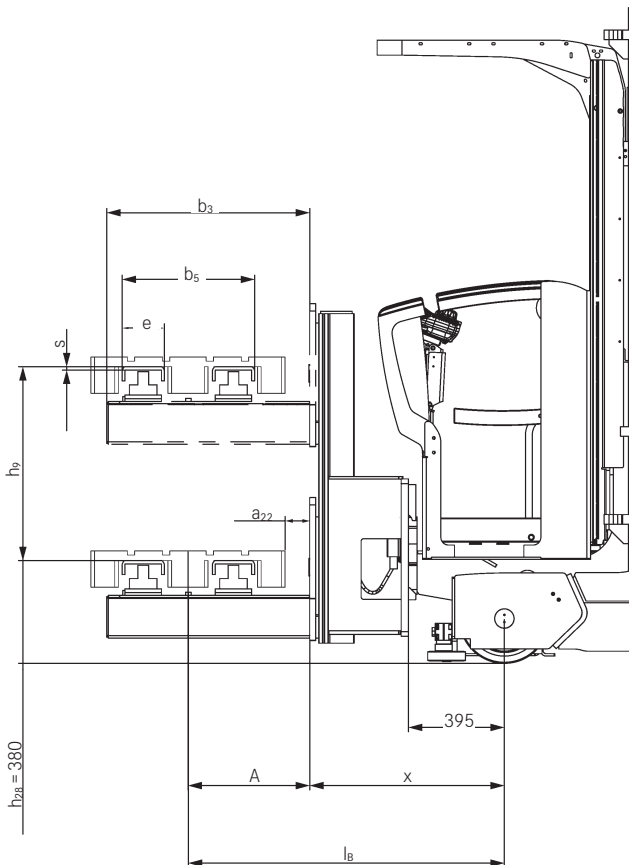

MX-X with high telescopic fork - side view

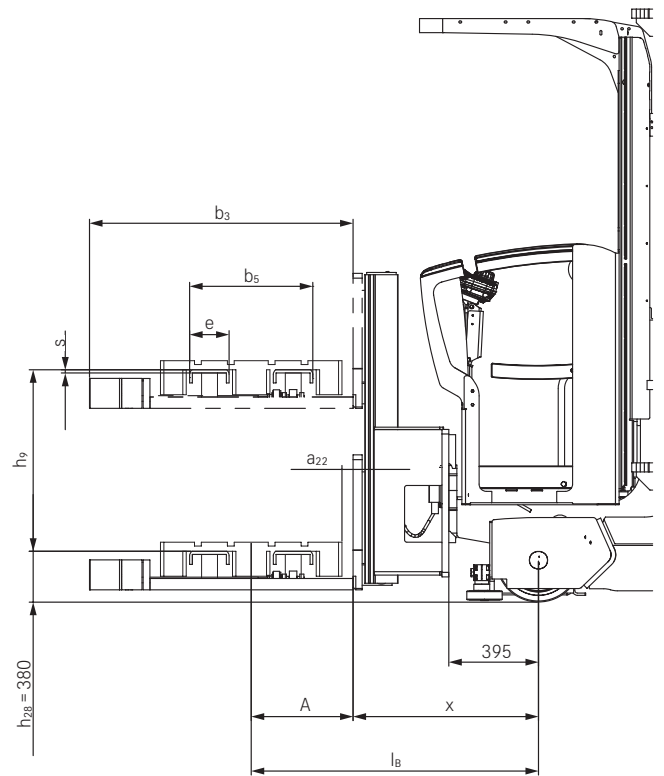

MX-X with low telescopic fork - side view

## MX-X Very Narrow Aisle Truck (man-up) Mast Tables

### MX-X with turret head

Telescopic mast (all heights indicated in mm)

Overall height $h_1$	Overall lift above floor $h_{25} (h_3 + h_9 + h_{13})$	Overall lift $h_{24} (h_3 + h_9)$	Lift $h_3$	Height lowered $h_{13}$	Auxiliary lift $h_9$	Stand height $h_{12} (h_3 + h_7)$	Reach height $h_{28} (h_{12} + 1600)$	Maximum height $h_4$
2400	4060	4000	2200	60	1800	2660	4260	4785
2900	5060	5000	3200	60	1800	3660	5260	5785
3400	6060	6000	4200	60	1800	4660	6260	6785
3900	7060	7000	5200	60	1800	5660	7260	7785
4400	8060	8000	6200	60	1800	6660	8260	8785
4900	9060	9000	7200	60	1800	7660	9260	9785
5400	10060	10000	8200	60	1800	8660	10260	10785
5900	10860	10800	9000	60	1800	9460	11060	11585
6400	11860	11800	10000	60	1800	10460	12060	12585
6900	12660	12600	10800	60	1800	11260	12860	13385
7400	13660	13600	11800	60	1800	12260	13860	14385

Triplex mast with free lift (all heights indicated in mm)

Overall height $h_1$	Overall lift above floor $h_{25} (h_3 + h_9 + h_{13})$	Overall lift $h_{24} (h_3 + h_9)$	Lift $h_3$	Height lowered $h_{13}$	Auxiliary lift $h_9$	Stand height $h_{12} (h_3 + h_7)$	Reach height $h_{28} (h_{12} + 1600)$	Maximum height $h_4$
2900	6910	6850	5050	60	1800	5510	7110	7635
3400	8210	8150	6350	60	1800	6810	8410	8935
3900	9310	9250	7450	60	1800	7910	9510	10035
4400	10610	10550	8750	60	1800	9210	10810	11335
4900	11910	11850	10050	60	1800	10510	12110	12635
5400	13410	13350	11550	60	1800	12010	13610	14135
5900	14710 <sup>1</sup>	14650	12850	60	1800	13310	14910	15435
6400	16210 <sup>1</sup>	16150	14350	60	1800	14810	16410	16935
6900	17510 <sup>1</sup>	17450	15650	60	1800	16110	17710	18235

<sup>1</sup> Lift  $h_{25}$  for iGo systems vehicles: up to 14,000 mm

### MX-X with telescopic fork

Telescopic mast (all heights indicated in mm)

Overall height $h_1$	Overall lift above floor $h_{25} (h_3 + h_9 + h_{13})$	Overall lift $h_{24} (h_3 + h_9)$	Lift $h_3$	Height lowered $h_{13}$	Auxiliary lift $h_9$	Stand height $h_{12} (h_3 + h_7)$	Reach height $h_{28} (h_{12} + 1600)$	Maximum height $h_4$
2400	3380	3000	2200	380	800	2660	3860	4755
2900	4380	4000	3200	380	800	3660	4860	5755
3400	5380	5000	4200	380	800	4660	5860	6755
3900	6380	6000	5200	380	800	5660	6860	7755
4400	7380	7000	6200	380	800	6660	7860	8755
4900	8380	8000	7200	380	800	7660	8860	9755
5400	9380	9000	8200	380	800	8660	9860	10755
5900	10180	9800	9000	380	800	9460	10660	11555
6400	11180	10800	10000	380	800	10460	11660	12555
6900	11980	11600	10800	380	800	11260	12460	13355
7400	12980	12600	11800	380	800	12260	13460	14355

Triplex mast with free lift (all heights indicated in mm)

Overall height $h_1$	Overall lift above floor $h_{25} (h_3 + h_9 + h_{13})$	Overall lift $h_{24} (h_3 + h_9)$	Lift $h_3$	Height lowered $h_{13}$	Auxiliary lift $h_9$	Stand height $h_{12} (h_3 + h_7)$	Reach height $h_{28} (h_{12} + 1600)$	Maximum height $h_4$
2900	6230	5850	5050	380	800	5510	7110	7605
3400	7530	7150	6350	380	800	6810	8410	8905
3900	8630	8250	7450	380	800	7910	9510	10005
4400	9930	9550	8750	380	800	9210	10810	11305
4900	11230	10850	10050	380	800	10510	12110	12605
5400	12730	12350	11550	380	800	12010	13610	14105
5900	14030 <sup>1</sup>	13650	12850	380	800	13310	14910	15405
6400	15530 <sup>1</sup>	15150	14350	380	800	14810	16410	16905
6900	16830 <sup>1</sup>	16450	15650	380	800	16110	17710	18205

<sup>1</sup> Lift  $h_{25}$  for iGo systems vehicles: up to 14,000 mm



MX-X Very Narrow Aisle Truck (man-up)  
Detailed Photos



Individually adjustable rear view mirrors for easy access into the aisles

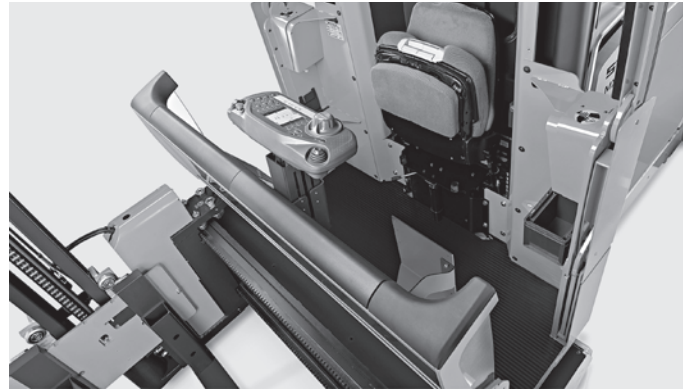

Comfortable work standing and seated



Compact and ergonomic control panel with colour display and driver information



Three-dimensional positioning of the control panel



Tilting bar for ergonomic order picking to the last article on the pallet



Upholstered knee protector and cup holder for comfortable work



Versatile support system for individual work spaces

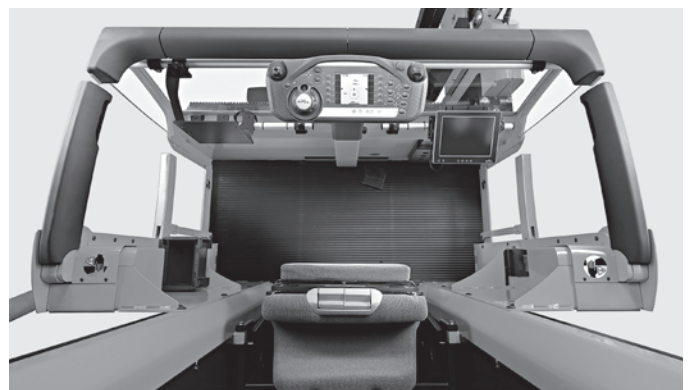

Spacious work space with multiple supports for accessories

## MX-X Very Narrow Aisle Truck (man-up) iGo pilot

---

The right system for any customer requirement: STILL iGo pilot can read RFID tags and barcode labels

Custom configuration: the system can be individually adapted to any conceivable very narrow-aisle warehouse

Optimal working conditions: doing away with search processes and wasted trips relieves the burden on the operator and enables quick incorporation of new employees

# iGo pilot

### STILL iGo pilot - Performance profile at a glance

---

The iGo pilot navigation and iGo pilot safety functions link the specific warehouse topography to the trucks operating within.

The iGo pilot navigation interface communicates with the warehouse management system and combines the warehouse processes into an intelligent whole. As a result, the truck knows which high shelving location to drive to next, thus unburdening the operator. When the operator accepts the next order, the truck finds its own way through the warehouse aisles. Thanks to iGo pilot safety assistance and warning systems, which can be individually preconfigured to any warehouse,

the truck proactively adapts to its route as well as to local conditions and potential hazards. Once the truck has arrived at its destination, iGo pilot navigation stops the fork at exactly the right shelf position according to the task at hand. Once the task has been completed, the data is sent back to the warehouse management system in order to prevent order-picking errors and incorrect storage or retrieval of pallets. The result is a significant increase in handling capacity as well as increased safety thanks to networked agility.

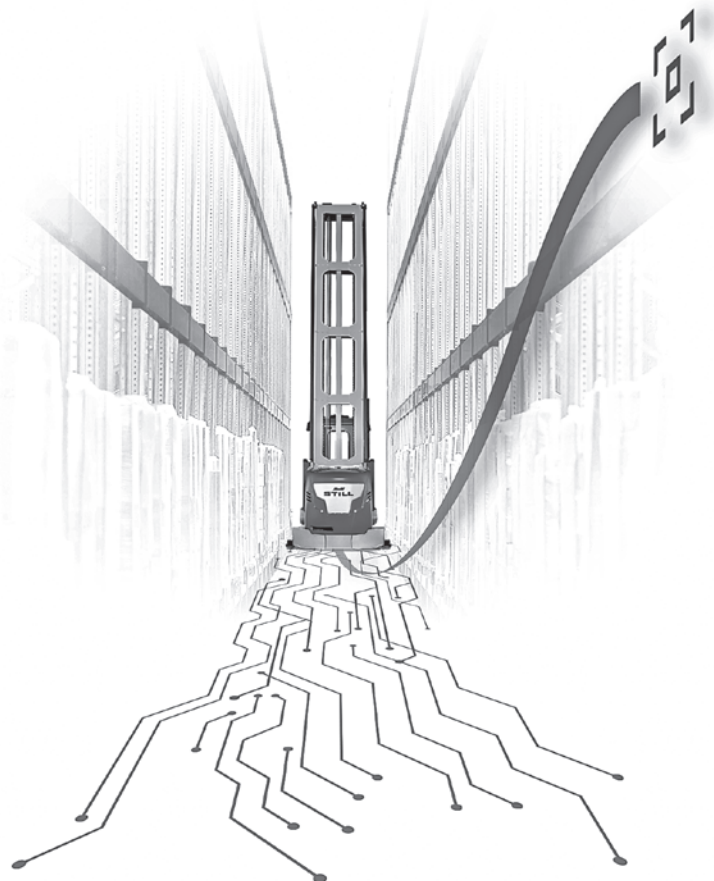

## MX-X Very Narrow Aisle Truck (man-up) iGo pilot

Easy to use: destinations can be entered via scanner, terminal or online from the warehouse management system, and the process is started with just one movement of the drive lever

Supreme productivity: the truck automatically navigates to its destination along the ideal route, regardless of the experience and knowledge of the operator

Smart precision: the truck moves to exactly the right pallet position, with the possibility of preventing fork movements when not required in order to prevent storage and retrieval errors

# iGo pilot navigation

iGo pilot navigation leads the operator in their very narrow aisle truck along the ideal route to the desired pallet position. This is possible thanks to a three-dimensional shelving plan that maps the specific topography of the warehouse. By comparing against this map stored in the system, the truck detects its current location in the aisle as well as its position. iGo pilot navigation adjusts to the activities of storage,

retrieval and order-picking. As soon as an order comes in, the system determines the optimal horizontal and vertical route to the desired shelf location. By means of an optical display, the operator can see his current position in relation to the destination. He can only move his truck in the direction indicated. If he is in the wrong aisle, the display will flag this up to them.



Thanks to the variety of safety functions, the driver assistant protects goods, shelves, building equipment and the truck from damage

Always ready for action: reduced downtime by avoiding impact damage and the resulting repairs

Through a simplified workflow, the driver can fully concentrate on his core activity storage and retrieval or order-picking

# iGo pilot safety

If iGo pilot safety is installed, the operational safety and handling capacity of STILL very narrow aisle trucks are both significantly improved. Moreover, areas in the very narrow aisle warehouse where special safety regulations apply are defined in advance. A three-dimensional map of these areas is stored in the truck. This mapping is provided by STILL. This allows to masterfully handle obstacles in

the shelving aisle, required braking distances at the end of aisles and height restrictions during everyday operations. In addition, the truck constantly identifies its current position using the map. During its journey, the truck detects every warehouse aisle and their specific conditions and adapts to these without the operator having to intervene. The system always follows the predefined safety rules.



## MX-X Very Narrow Aisle Truck (man-up) iGo systems

Maximum safety: smart safety functions increase transport quality and eliminate risks of accidents and damage to people, vehicles, storage equipment and goods

Outstanding process excellence: avoiding mispicks and empty runs increases transport quality

Maximum availability: efficient transport control and IT integration enable optimal fleet utilisation around the clock

Optimum cost-effectiveness and efficiency through individual automation concepts as well as transparent and optimised continuous material flow



### iGo systems - Automated transport solutions

STILL iGo systems enables automated interaction between one or more different trucks so that transport tasks in the warehouse can be performed without a driver. No matter what your transport task, we have the right automated truck for you. The various trucks in the iGo systems portfolio assist with incoming and outgoing goods, storage, buffering, order picking, as well as production supply and disposal. The iGo software takes over control and traffic regulation tasks, achieves effective fleet utilisation and monitors all battery charge statuses. Modern navigation technology is used to guide the trucks through the warehouse. Personnel protection scanners ensure

the highest level of safety, while suitable sensors accurately detect pallets. The fully automated STILL devices cooperate effectively with manually controlled and semi-automated transport systems. Automation kits with standardised components, controls and interfaces transform a series truck into an industrial AGV (automated guided vehicle). We offer you reliable and scalable solutions across the entire automation spectrum. With your return on investment always in mind, we will support you all the way: from conception and quoting to implementation and maintenance.





---

### Advantages of automated very narrow aisle trucks

---

Maximum performance and safety in the most confined spaces - a given with very narrow aisle trucks such as the MX-X iGo systems. This truck sets standards wherever the available space is to be used optimally. Its narrow aisle width and automated load cycles up to a height of 14 metres at a load capacity of 1,400 kg enable a particularly high degree of space utilisation as well as top-level handling performance.

With absolute precision, maximum safety and stability even at lofty heights, the MX-X iGo systems is the perfect partner for reliable automated warehouses. Fully automated, the vehicle increases efficiency and minimises the susceptibility to errors when storing and retrieving heavy loads at great heights. Maximum safety is achieved with the following integrated safety features: Safety laser scanners to detect people and objects in the path of travel, optical and acoustic

warning devices (e. g. when changing direction) as well as several emergency stop switches to stop the vehicle immediately. The automated STILL trucks can be easily connected to your own systems, e. g. for warehouse management. Automation kits with standardised components, controls and interfaces turn a series-produced truck into an industrialised AGV (automated guided vehicle). In this context, the following is particularly important to us: Not every technological innovation is the economically appropriate one for your task. We offer you reliable and scalable solutions for your automation requirements - precisely tailored to your intralogistics. We always keep your return on investment in mind. From conception to implementation and maintenance, we work with you as partners and make sure that you will not get lost in the jungle of digital Industry 4.0 options.

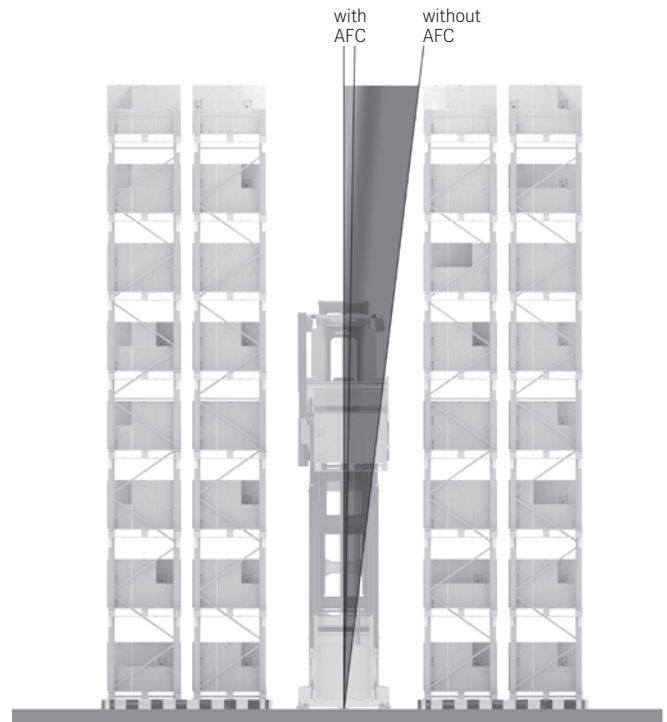
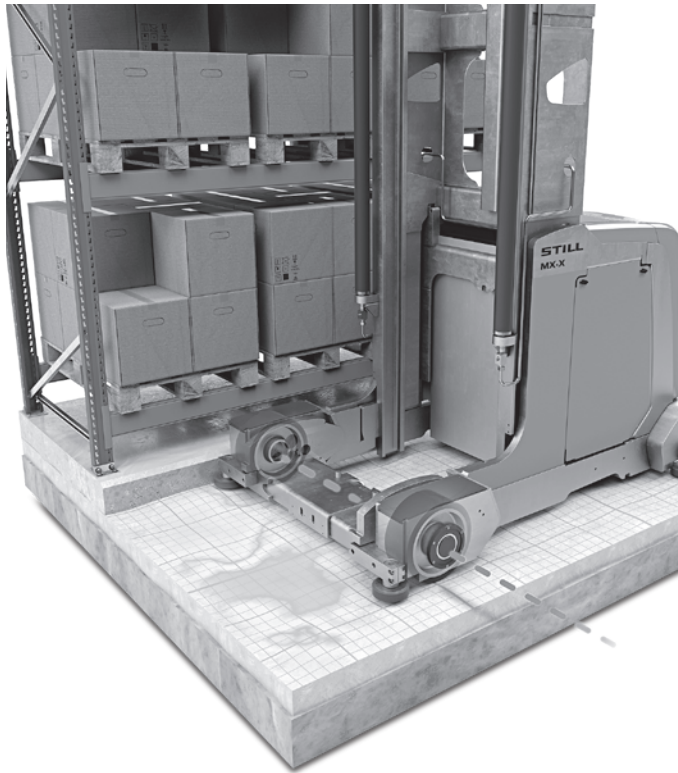

## Active Floor Compensation (AFC)

### **Active Floor Compensation (AFC) – Maximum performance also with uneven floors.**

For narrow-aisle warehouses, there are particularly high demands on the evenness of the floor. Should they be uneven or have any traces of wear, these will be transferred directly to the forklift truck in the form of vibrations. For maximum speeds and efficiency to be achieved, the floor needs to be absolutely level. Reconditioning the floor is not only costly, it also prevents the warehouse from being fully utilised while the work is being carried out.

#### **Active assistance system: AFC**

With the assistance system for the MX-X Very Narrow Aisle Truck, STILL offers a genuine alternative to reconditioning the warehouse floor. The

system identifies any uneven surfaces in the load wheels' path and compensates for them in real time. This ensures that the truck frame always remains horizontal and the mast vertical. The AFC system – the only one of its kind on the market – has ultra-fast processors which allow it to react instantaneously, even when travelling at top speeds. In contrast to passive systems that only have a dampening effect, this system actively prevents vibrations before they occur.

**Reduced vibrations – higher handling performance.** Preventing mast vibrations protects the load, the warehouse and the driver and, last but not least, facilitates a significant increase in handling capacity with the help of AFC.

## Active Load Stabilisation (ALS)

### **Unique around the world: STILL Active Load Stabilisation (ALS):**

Active load stabilisation is unique in narrow aisle operations. It not only increases comfort, but also optimises the pushing movement when

loading and picking. The hydraulic control inhibits mast vibrations and increases handling capacity by up to 5 percent.



## MX-X Very Narrow Aisle Truck (man-up) Perfection in Performance and Comfort

Optimum use of storage space: 18-metres lift height and highest residual load capacity

Fast storage and retrieval: Active load stabilisation (ALS) to reduce mast oscillations

Maximum possible working comfort: Spacious and flexibly adjustable driver's cabin

Maximum travel speeds: Active Floor Compensation (AFC) compensates for uneven ground

Innovative technologies and smart modularity: The STILL MX-X VNA Very Narrow Aisle Truck (man-up) sets standards in performance and user-friendliness. Developed to optimally handle any challenge, the MX-X scores with performance packages for every application profile. Thus you receive a truck precisely adapted to your individual requirements - from its dimensions to its technical features. The focus is on the operator: A spacious and flexibly adaptable driver's cabin, intuitive controls and smart assistance systems promise safe, comfortable and efficient work throughout a whole shift.

Driving speeds of up to 14 km/h, a lift height of up to 18 metres and the highest residual load capacity on the market make the MX-X a turnover champion in highly compacted warehouse worlds. Whilst the active load stabilisation (ALS) notably shortens storage and retrieval processes by up to 5%, the mechanism of the turret head promises even shorter picking distances. Thanks to the fully welded auxiliary lift, the MX-X scores with maximum stability throughout its service life. The STILL MX-X high bay order pickers can be individually configured according to your requirements and will thrill you with their excellent functionality.



#### Simply easy

---

- Intuitive vehicle comprehension as well as safe and ergonomic operation thanks to the compact control panel with colour display, visual instructions and individual definition of favourites
- Customised and space-optimised design of the driver's cab with multifunctional bars and holders to fasten small load carriers in the driver's compartment
- Ergonomic order picking: small distance between driver's cab and load carrier guarantees optimum power transmission

#### Simply powerful

---

- Maximum turnover rates through configurable performance packages. In addition, various OptiSpeed options are available to increase performance, e. g. active load stabilisation (ALS) when operating the push function
- Maximum storage density: thanks to the massive chassis, the MX-X has a particularly high residual load capacity and can store even heavy goods high up
- Particularly high degree of space utilisation due to the lifting height of more than 18 metres
- Compensation of uneven floors even at high travel speeds thanks to Active Floor Compensation (AFC) as a cost-effective alternative to floor renovation
- Absolute availability: can be used with various batteries (lead-acid and lithium-ion) in 48 V and 80 V, and thus a real power pack even in multi-shift operation
- In the Blue-Q efficiency programme, the MX-X also saves energy at the touch of a button - without any drop in performance

#### Simply safe

---

- Twofold protection: sensor-controlled two-hand operation and electronic monitoring of the battery lock provide safety at work

- The shock-absorbing floor in the driver's cab and the foot section facing the load side ensure a high level of user comfort and health protection
- Accident prevention with Rescue Alarm, Safety Light and the optional iGo pilot safety function: the alarm system reacts sensitively to abnormal driver behaviour in narrow aisles, the lighting system increases the vehicle's visibility to third parties, and the pedestrian protection system (PPE) prevents accidents caused by carelessness
- Continual high performance at a consistently low noise level: particularly quiet drive and lift motors ensure minimal noise impact on the driver

#### Simply flexible

---

- Customised very narrow aisle trucks with individually configured vehicle dimensions and cabin variants enable high warehouse density and a high degree of utilisation diversity for all requirements
- High functionality in goods accessibility: optional tiltable side barrier facilitates ergonomic access to goods up to the last item

#### Simply connected

---

- Minimise errors and increase throughput at the same time by using the iGo pilot navigation assistance system for automatic approach to the shelf
- Compact overview of all relevant vehicle information in the STILL neXXt fleet web application
- Optimisation of the flow of goods through uncomplicated connection to the company's own warehouse management system (WMS) with the iGo pilot navigation interface





# MX-X Very Narrow Aisle Truck (man-up) Equipment Variants



		MX-X With turret head	MX-X With telescopic fork	
Driver's seat	Ergonomic, shock absorbing seat with horizontal and tilt adjustment	●	●	
	Seat variants with arm rests and heating or air-suspended comfort seat	○	○	
	Shock-absorbing work space for optimum comfort on bumpy floors and trespasses	●	●	
	Combi cabin for freedom of movement when order picking or stacking	●	●	
	Comfort cabin for greatest freedom of movement	○	○	
	Many different cabin widths (1,070-1,970 mm)	●	●	
	Cold store version for temperatures up to -30 °C	○	○	
	Heights overhead guard 1,900/2,000/2,100 mm	○/●/○	○/●/○	
	Single centrally placed control panel with ergonomic steering knob to control the truck	●	●	
	Two-piece control panel integrated in the armrests of the seat for seated and standing driving	○	○	
	Colour display to indicate operating states	●	●	
	Tilting barrier for optimum reach	○	○	
	Full glass swivel door for the closed cabin	○	○	
	Upholstered backrest for standing truck operation	●	●	
	Knee upholstery for support when order picking	○	○	
	Mounting support to attach storage compartments for small utensils (load end and/or lift end)	○	○	
	Flexible bar system for individual work space layout (load end and/or mast end)	○	○	
	Adjustable rear view mirrors, optionally with integrated LED lighting and fans	○	○	
	LED lights to light the cabin	○	○	
	LED spot light for the rack	○	○	
	Reversing camera system with 180° field of vision consisting of one or two cameras	○	○	
	Integrated storage compartments, for example for writing pad, bottles, or USB socket	○	○	
	Prepared for installation of standard car radios	○	○	
	Electric and mechanic preparation for data terminal	○	○	
	Performance packages	OptiSpeed 3.0: Basic equipment with reach control	●	●
		OptiSpeed 3.1: Load detection for speed optimisation	○	○
		OptiSpeed 3.3: Weight and load detection for speed optimisation	○	○
		OptiSpeed 3.4: Active load stabilisation and weight and load detection for speed optimisation	○	○
STILL iGo pilot navigation: semi-automatic approach to shelf		○	○	
Active Floor Compensation (AFC): Assistance system to compensate for uneven floors for maximum driving speed		○	○	
Performance package lifting		○	○	
Performance package driving		○	○	
Safety	STILL iGo pilot safety: tailor-made safety and flexibility in the narrow aisle	○	○	
	FleetManager: access authorisation, shock detection, reports	○	○	
	Rescue Alarm for atypical user input to attract attention	○	○	
	Reach control depending on lift height and load weight for safe storage and retrieval	●	●	
	Automatic end-of-aisle stop with pedestrian protection system, RFID tags or magnetic switches	○	○	
	Rail guidance with entrance rollers	●	●	
	Inductive guidance with automatic loop finder	○	○	
	Increased residual load capacity for heavy loads at large heights	○	○	
	Automatic fork cycle for faster and safer load change, integrated in the control panel	○	○	
	Lift height pre-selection for faster positioning at the storage bay and for stacking	○	○	
	PIN code access, keyless with push button	○	○	
	Warning light, drive end for better perception of the truck	●	●	
	Warning light, load end	○	○	
	STILL Safety Light	○	○	
	Acoustic warning when driving in load and/or drive direction	○	○	
	Adjustable lift cutoff and lowering stop	○	○	
	Contactless collision guard on the OHG	○	○	
	Installed rope rescue system, ready for use	●	●	
Maximum safety through iGo systems automation	○	○		
Hydraulics	Over shift function for turret head	○	—	
	Symmetric hydraulic fork arm adjustment	○	—	
	Parallel hydraulic fork arm adjustment	○	—	
	Hydraulic fork arm adjustment single fork arm	○	—	
	Auxiliary functions attachment	○	—	
	Mast transition damping	●	●	
	Auxiliary lift h <sub>9</sub>	●	●	
	Noise-optimised hydraulic pump	●	●	
	Energy recovery when lowering	●	●	
Drives	Jerk-free, stepless acceleration up to top speed	●	●	
	Maintenance-free drives for driving, steering and lifting	●	●	
	Fully capsulated, dirt and dust resistant components	●	●	
	Regenerative brake system for energy recuperation when braking	●	●	
	Additional hydraulic load wheel brake	○	○	
Battery	48-V battery compartment for 480 to 1240 Ah	○	○	
	80-V battery compartment for 360 to 930 Ah	○	○	
	Li-Ion Ready for the 48-V battery compartment	○	○	
	Battery roller track for lateral battery change	○	○	
	Electronic battery lock monitor	●	●	
	Preparation for fast charging access	○	○	
Fast charging access	○	○		

● Standard ○ Option — Not available



STILL GmbH  
Berzeliusstr. 10  
22113 Hamburg  
Germany  
Tel.: +49 40 73 39 20 00  
Fax: +49 40 73 39 20 01  
info@still.de

**For further information please visit**  
**[www.still.eu](http://www.still.eu)**

STILL is certified in the following areas: Quality management, occupational safety, environmental protection and energy management.



first in intralogistics