

1-2 Pallet Handlers

Models 12PH



Multiple Pallet Handler are used in all industries characterized by heavy handling of palletized loads and in particular warehouse, food and beverage, and brick industries.

The Bolzoni Auramo 1-2 Pallet Handlers allow the handling of more loads in less time, increasing productivity and reducing handling costs during storage or loading and unloading of vehicles.

Superior visibility on fork tips across and above the chassis, allows fast, safe and damage-free handling.

Designed with optimized number of high quality components for easy and fast replacement of parts subject to wear, allowing a reduction in service costs.

Thanks to the specific features and to a wide range of capacities and fork openings, the Bolzoni Auramo 1-2 Pallet Handlers offer great flexibility of use and applications and represent a reliable and efficient solution to today's most demanding handling needs.

The Bolzoni Auramo introduces the new **profile guided concept**: model **12PH**.

The unique Profile Concept combines exceptional durability, highest operational flexibility with an optimum visibility and minimal Life Cycle Cost in Full Maintenance Operations.

Features:

- **Extreme Durability** – successfully tested with more than 1 million load cycles with double the normal load capacity.
- **Torsion resistant steel profiles** for permanently safe transportation.
- **Optimum visibility design** – lowest chassis height with maximum openings through and underneath the chassis.
- **Safe Handling** – the perfect match for handling pallets.
- **Easy conversion of the ITA mounting class** (ITA 2 and 3 included as standard) - ideal for fleet users, and rental fleets for alternating applications logistic and rental fleet operation.
- **Reduced wear parts cost**, applicable without gas spring for GMA pallets.



1-2 Pallet Handlers, Profile Type

Models 12PH (Sideshifting)

Range: 5,500 - 7,000 Lbs.

Features:

- Single/double pallet handler for handling one or two loads for increased efficiency.
- Durable design for even hardest applications.
- Torsion resistant profiles for stable pallet transport.
- High visibility for safe handling.
- Synchronized fork travel by flow divider for perfect fit to pallet drive-in measurements.
- Dual Mounting Concept for highest flexibility.
- Lowest life time cost thanks to high quality wear components and service optimized engineering.

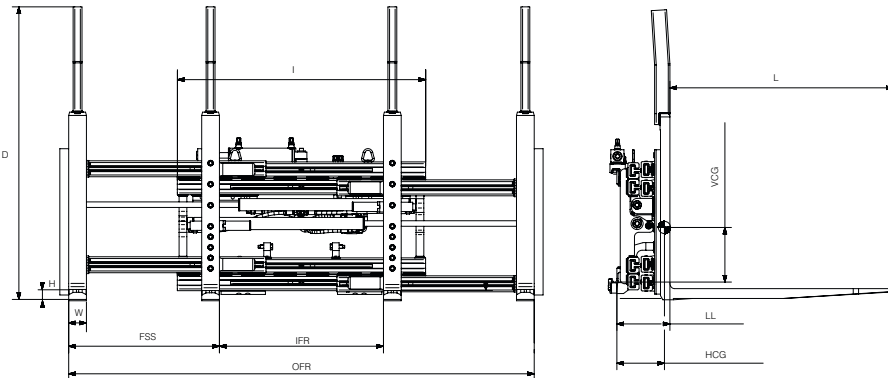

Model	Capacity Lbs. @ 24"	Fork Set Spread	Outer Fork Range	Inner Fork Range	Fork Dimensions	Frame Width	Minimum Carriage Width	Height	Weight Lbs.	Effective Thickness	Horizontal Center of Gravity	Vertical Center of Gravity	Mounting Class
	Q	FSS	OFR	IFR	L x w x h ①	I	FL	D	W	LL	HCG	VCG	
Beverage 36" x 36"													
12PH55SA-1B	5,500	24"	26" - 81"	13" - 33"	36" x 3.2" x 1.8" - 1.6"	44.1"	36"	48"	1,153	9.6"	7.0"	12.0"	II
12PH55SB-1B	5,500	24"	26" - 81"	13" - 33"	36" x 3.2" x 1.8" - 1.6"	44.1"	36"	48"	1,149	9.5"	7.0"	12.0"	III
12PH70SB-1B	7,000	24"	26" - 81"	13" - 33"	36" x 3.2" x 2.4" - 2.2"	44.1"	36"	48"	1,275	10.1"	8.4"	12.4"	III
GMA & Chep Block 40" x 48"													
12PH55SA-1G	5,500	27"	28" - 83"	15" - 29"	42" x 3.2" x 1.8" - 1.6"	44.1"	36"	48"	1,174	9.6"	7.0"	12.0"	II
12PH55SB-1G	5,500	27"	28" - 83"	15" - 29"	42" x 3.2" x 1.8" - 1.6"	44.1"	36"	48"	1,170	9.5"	7.0"	12.0"	III
12PH70SB-1G	7,000	27"	28" - 83"	15" - 29"	42" x 3.2" x 2.4" - 2.2"	44.1"	36"	48"	1,323	10.1"	9.0"	13.0"	III
Container 44" x 56"													
12PH55SA-1C	5,500	24"	26" - 81"	13" - 33"	54" x 3.2" x 1.8" - 1.6"	44.1"	36"	48"	1,240	9.6"	7.5"	13.2"	II
12PH55SB-1C	5,500	24"	26" - 81"	13" - 33"	54" x 3.2" x 1.8" - 1.6"	44.1"	36"	48"	1,236	9.5"	7.5"	13.2"	III
12PH70SB-1C	7,000	24"	26" - 81"	13" - 33"	54" x 3.2" x 2.4" - 2.2"	44.1"	36"	48"	1,389	10.1"	10.0"	14.2"	III

Notes:

- Two hydraulic functions required for sideshifting model.
- Total sideshift 8".
- Mountings: Standard ITA mounting. For special mountings, consult Bolzoni Auramo.
- Attention: These attachment models are designed for load handling on forks only. Not suitable for clamping.
 - ① 1.6" outer forks - 1.4" inner forks (4,800# cap.)
 - 1.8" outer forks - 1.6" inner forks (5,500# cap.)
 - 2.4" outer forks - 2.2" inner forks (7,000# cap.)

Options:

- Quick lower hooks Class 2&3
- Dual Mounting Adaptor Kit
- Alternative fork lengths or sections.
- Alternative opening / closing ranges or fork spreads.
- Design available without Pneumatic Springs for GMA & Chep Block handling.
- Alternative load backrests.
- Alternative available without sideshift.



BOLZONI AURAMO INC.
 17635 HOFFMAN WAY - HOMEWOOD, ILLINOIS 60430 -
 USA - Tel. 800-358-5438 - Fax. 708-957-8832
us.bolzonigroup.com

7711 HIGHWAY 278, SULLIGENT, ALABAMA 35586 -
 USA - Tel. 205 698-1231
sales.us@bolzoni-auramo.com

